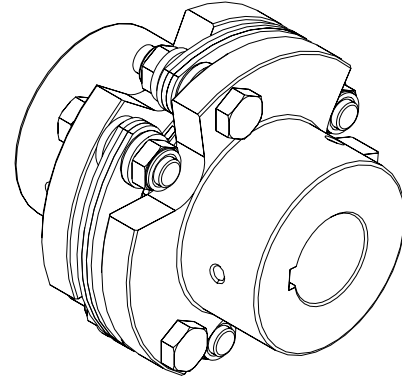


**Table of contents**

<u>Pg</u>	<u>Description</u>
1	Installation Procedure
2	Assembly Specifications
3	Hub installation Specifications
4	Parts List



**Installation Instructions for Composite Disc Couplings**

**Single Flex Series 6A**

1. Mount coupling hubs on the shafts. Be sure there are no burrs on the shafts or keys (if used).
2. Adjust hub separation to the dimension specified in the Table 1 and diagram 1. If possible, the shafts should not extend beyond the inside hub face. Tighten hubs to shafts (See Table 2 and Table 3 for proper tightening torque). If installing QD bushing hubs see “QD Bushing Hub Assembly” on page 3 and QD bushing manufacturer’s instruction sheet for further installation instructions.
3. Align the shafts to within the limits for parallel and angular misalignment specified in Table 1. See diagrams 2 and 3 for recommended measurement and alignment methods.

For best alignment results, use a dial indicator. Always rotate the hub on which the indicator is mounted.

Coupling and shaft alignment should be checked periodically due to foundation settling, equipment shifting, etc. Alignment should be re-checked after the first several hours of operation.

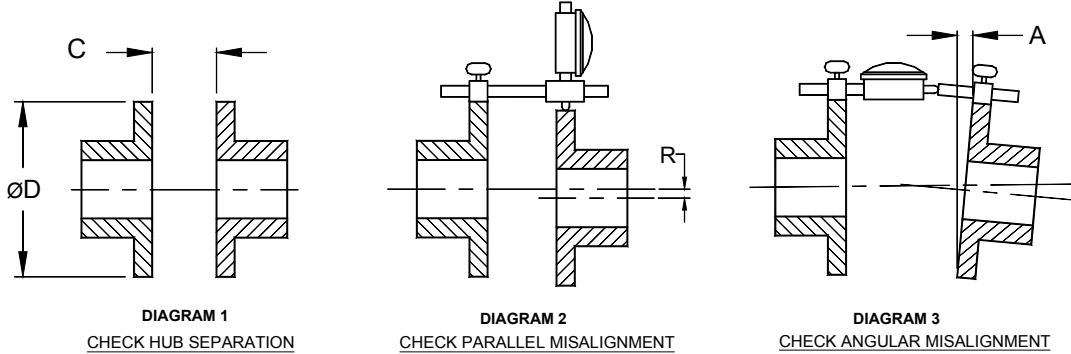
4. Install the disc pack between the hubs. Three bolts connect the disc pack to each hub (6 bolts total). Insert the bolts thru the 3 holes of each hub and tighten the locknuts per the Table 1 tightening torque specifications. Tighten the locknuts of one hub, then those of the other hub to approximately ½ the stated torque value. Next repeat the process but tightening to the full torque value. It is also recommended to apply torque on the locknut, not the bolt. Re-check and tighten all fasteners after several hours of operation to ensure proper tightening.

**\*NOTE:** Aligning the shafts as closely as possible at the time of initial installation will allow the coupling extra capacity for misalignments and loads which will occur during operation over the life of the connected equipment. Installing and operating the coupling at higher degrees of misalignment is possible (see catalog ratings), but will generally reduce the life of the flex disc pack.

**\*NOTE: Rotating equipment is potentially dangerous and should be properly guarded. The user should follow all applicable safety codes and provide a suitable guard.**

# ////// ZERO-MAX

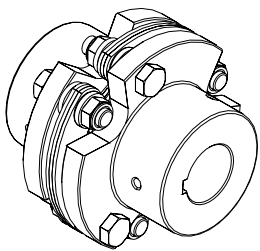
MOTION CONTROL PRODUCTS



**Table 1**  
Alignment and Assembly Specifications for Single Flex Series 6A

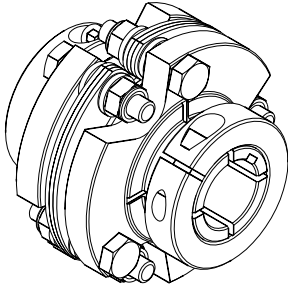
Model	Recommended maximum installed misalignments						Tightening Torque (Dry values)		Unit Outside Diameter Ø D	
	C See Diagram 1		R See Diagram 2		A See Diagram 3				Inch	mm
	Inch	mm	Inch	mm	Inch	mm				
6A18	0.276±0.010	7.01±0.25	0.001	0.03	0.016	0.41	17-19 in lb	205 Ncm	1.85	47.0
6A22	0.306±0.012	7.77±0.30	0.002	0.05	0.020	0.50	45-50 in lb	540 Ncm	2.25	57.2
6A26	0.306±0.015	7.77±0.38	0.003	0.08	0.023	0.58	45-50 in lb	540 Ncm	2.59	65.9
6A30	0.460±0.017	11.68±0.43	0.003	0.08	0.026	0.66	90-95 in lb	10.5 Nm	3.00	76.2
6A37	0.522±0.023	13.26±0.58	0.004	0.10	0.033	0.83	225-235 in lb	26 Nm	3.75	95.3
6A45	0.582±0.030	14.78±0.76	0.005	0.13	0.039	1.00	36-38 ft lb	51 Nm	4.50	114.3
6A52	0.646±0.037	16.41±0.94	0.006	0.15	0.046	1.20	36-38 ft lb	51 Nm	5.25	133.4
6A60	0.768±0.043	19.51±1.09	0.007	0.18	0.052	1.30	64-68 ft lb	89 Nm	6.00	152.4
6A67	0.860±0.050	21.84±1.27	0.007	0.18	0.059	1.50	64-68 ft lb	89 Nm	6.75	171.5
6A77	1.012±0.053	25.70±1.35	0.008	0.20	0.068	1.70	155-160 ft lb	215 Nm	7.75	196.9
6A90	1.134±0.060	28.80±1.52	0.010	0.25	0.079	2.00	305-315 ft lb	420 Nm	9.00	228.6
6A105	1.446±0.070	36.73±1.78	0.012	0.30	0.092	2.30	530-540 ft lb	725 Nm	10.50	266.7
6A120	1.536±0.083	39.01±2.11	0.013	0.33	0.105	2.70	530-540 ft lb	725 Nm	12	304.8

**Table 2**  
Set Screw Torque Table

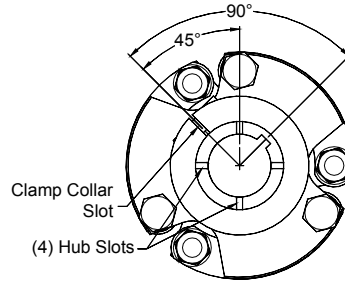


**Fig. 1**  
Set Screw Style Hub

Screw Size	Wrench Size	Torque (in lb)	Torque (Nm)
#10-32unf	0.094	36	4.1
¼-20unc	0.125	87	9.8
3/8-16unc	0.188	290	33
½-13unc	0.250	620	70
¾-10unc	0.375	2400	271
1"-8unc	0.563	5000	564
Metric			
M5 x 0.8	2.5mm	35	4.0
M6 x 1.0	3mm	64	7.2
M8 x 1.25	4mm	150	17
M10 x 1.50	5mm	290	33
M12 x 1.75	6mm	480	54
M20 x 2.50	10mm	2100	237
M24 x 3.00	12mm	3860	440



**Fig. 2**  
Clamp Style Hub



**Fig. 3**  
Clamp Slot Location

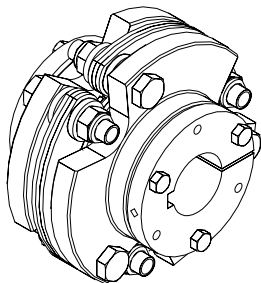
**Table 3**

Clamp Collar Bolt Torque Table

Clamp bolt Size	Wrench Size	Torque (in lb)	Torque (Nm)
1/4-28unf	0.188	170	19
5/16-24unf	0.250	325	37
3/8-24unf	0.312	570	64
1/2-20unf	0.375	1370	155
<b>Metric</b>			
M6 x 1.0	5mm	141	16
M8 x 1.25	6mm	345	39
M10 x 1.50	8mm	680	77

### Clamp Hub Assembly

Before tightening the clamp collar screw(s), orient the clamp collar slot (see Fig. 3) 90 degrees from the keyway centerline. If there is no keyway orient the clamp collar slot 45 degrees from one of the hub slots (see Fig. 3)



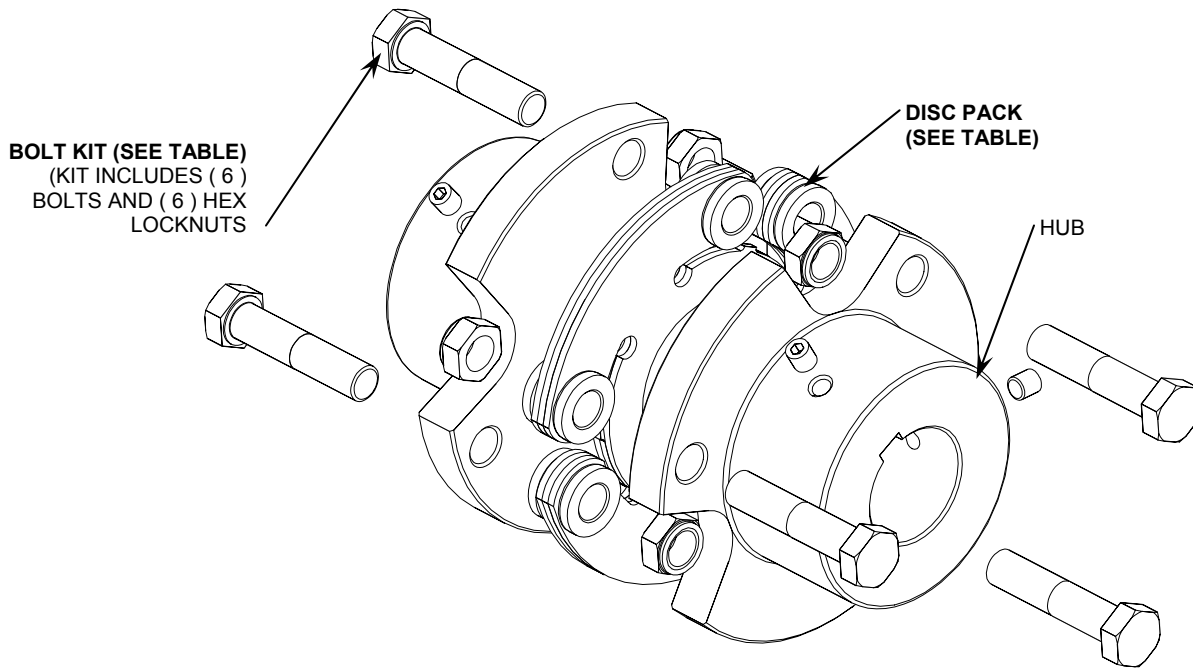
**Fig. 4**  
QD Bushing Style Hub

### QD Bushing Hub Assembly

When tightening the QD Bushing bolts the Hub will be pulled toward the bushing flange. The amount of movement is generally 0.06 to 0.10 inches (1.5 to 2.5mm) per hub. Install one hub/bushing assembly on the shaft and tighten the QD bushing to specifications. Place the second hub/bushing assembly on the shaft with a hub separation of 0.08 less than the "C" dimension shown in the Table 1 on page 2, See diagram 1. Torque the QD bushing bolts to the manufacturer's specification and verify hub separation and misalignment. Loosen bolt and adjust assembly as needed until hub separation and misalignment are within specifications. Consult QD bushing manufacturer's documentation for proper tightening torque and sequence.

# ////// **ZERO-MAX**

MOTION CONTROL PRODUCTS



**Fig. 5**

**Table 4**  
**Replacement Parts**

Model	Hub OD (inch)	Disc Pack		Bolt Kit	
		Qty	Part No	Qty	Part No
6A18	1.85	1	A018002	1	A018100
6A22	2.25	1	A022000	1	A022100
6A26	2.59	1	A026000	1	A026100
6A30	3.00	1	A030000	1	A030100
6A37	3.75	1	A037000	1	A037100
6A45	4.50	1	A045000	1	A045100
6A52	5.25	1	A052000	1	A052101
6A60	6.00	1	A060000	1	A060100
6A67	6.75	1	A067000	1	A067100
6A77	7.75	1	A077000	1	A077100
6A90	9.00	1	A090000	1	A090100
6A105	10.50	1	A105000	1	A105100
6A120	12.00	1	A120000	1	A120100